



# Agilent E1403C and Agilent E1407A C-Size Active Adapter Module

## Installation and User's Manual

### Where to Find it - Online and Printed Information:

System installation (hardware/software) .....	VXIbus Configuration Guide* Agilent VIC (VXI installation software)*
Module configuration and wiring .....	This Manual
VXIplug&play programming .....	VXIplug&play Online Help
VXIplug&play example programs .....	VXIplug&play Online Help
VXIplug&play function reference .....	VXIplug&play Online Help
Soft Front Panel information .....	VXIplug&play Online Help
VISA language information.....	Agilent VISA User's Guide
Agilent VEE programming information.....	Agilent VEE User's Manual



*\*Supplied with Agilent Command Modules, Embedded Controllers, and VXLink.*





Warranty .....	3
Safety Symbols .....	4
WARNINGS .....	4
Declaration of Conformity .....	5
User Notes .....	7
<b>Chapter 1</b>	
<b>General Information .....</b>	<b>9</b>
Introduction .....	9
C-Size Adapter Description .....	9
Agilent E1403C Adapter Description .....	9
Agilent E1407A Adapter Description .....	10
<b>Chapter 2</b>	
<b>Installation/Removal Instructions .....</b>	<b>11</b>
Preparing for Installation .....	11
Installing A-Size VMEbus Modules (Agilent E1403C Only) .....	11
Installing an Adapter Module with a B-Size VXIbus Module .....	12
Removing the Adapter Module and B-Size Module .....	15
<b>Chapter 3</b>	
<b>Using the Adapters .....</b>	<b>17</b>
Agilent E1403C Block Diagram .....	17
Agilent E1403C Connector Pinout .....	18
Agilent E1407A Block Diagram .....	19
Agilent E1407A Connector Pinout .....	20
Installing the J2 Connector Cable (Agilent E1407A Only) .....	21
Purpose of the J2 Cable .....	21
Install the J2 Cable .....	21
Ribbon Cable (J2) Connector Pinout .....	23
Selecting the TTL Trigger Direction (Agilent E1407A Only) .....	24
Selecting the ECL Trigger Direction (Agilent E1407A Only) .....	25
SUMBUS Configurations (Agilent E1407A Only) .....	26
Disconnecting the SUMBUS .....	26
Adding Buffer Circuitry to the SUMBUS .....	26
<b>Appendix A</b>	
<b>Agilent E1403C and Agilent E1407A Specifications .....</b>	<b>27</b>
Product Characteristics .....	27
Power Requirements .....	27
Cooling Requirements .....	27
<b>Index .....</b>	<b>29</b>



---

## Certification

*Agilent Technologies, Inc. certifies that this product met its published specifications at the time of shipment from the factory. Agilent Technologies further certifies that its calibration measurements are traceable to the United States National Institute of Standards and Technology (formerly National Bureau of Standards), to the extent allowed by that organization's calibration facility, and to the calibration facilities of other International Standards Organization members.*

---

### AGILENT TECHNOLOGIES WARRANTY STATEMENT

**PRODUCT:** E1403C and E1407A

**DURATION OF WARRANTY:** 1 year

1. Agilent warrants Agilent hardware, accessories and supplies against defects in materials and workmanship for the period specified above (one year). If Agilent receives notice of such defects during the warranty period, Agilent will, at its option, either repair or replace products which prove to be defective. Replacement products may be either new or like-new.
2. Agilent warrants that Agilent software will not fail to execute its programming instructions, for the period specified above, due to defects in material and workmanship when properly installed and used. If Agilent receives notice of such defects during the warranty period, Agilent will replace software media which does not execute its programming instructions due to such defects.
3. Agilent does not warrant that the operation of Agilent products will be interrupted or error free. If Agilent is unable, within a reasonable time, to repair or replace any product to a condition as warranted, customer will be entitled to a refund of the purchase price upon prompt return of the product.
4. Agilent products may contain remanufactured parts equivalent to new in performance or may have been subject to incidental use.
5. The warranty period begins on the date of delivery or on the date of installation if installed by Agilent. If customer schedules or delays Agilent installation more than 30 days after delivery, warranty begins on the 31st day from delivery.
6. Warranty does not apply to defects resulting from (a) improper or inadequate maintenance or calibration, (b) software, interfacing, parts or supplies not supplied by Agilent Technologies, (c) unauthorized modification or misuse, (d) operation outside of the published environmental specifications for the product, or (e) improper site preparation or maintenance.
7. TO THE EXTENT ALLOWED BY LOCAL LAW, THE ABOVE WARRANTIES ARE EXCLUSIVE AND NO OTHER WARRANTY OR CONDITION, WHETHER WRITTEN OR ORAL, IS EXPRESSED OR IMPLIED AND AGILENT SPECIFICALLY DISCLAIMS ANY IMPLIED WARRANTY OR CONDITIONS OF MERCHANTABILITY, SATISFACTORY QUALITY, AND FITNESS FOR A PARTICULAR PURPOSE.
8. Agilent will be liable for damage to tangible property per incident up to the greater of \$300,000 or the actual amount paid for the product that is the subject of the claim, and for damages for bodily injury or death, to the extent that all such damages are determined by a court of competent jurisdiction to have been directly caused by a defective Agilent product.
9. TO THE EXTENT ALLOWED BY LOCAL LAW, THE REMEDIES IN THIS WARRANTY STATEMENT ARE CUSTOMER'S SOLE AND EXCLUSIVE REMEDIES. EXCEPT AS INDICATED ABOVE, IN NO EVENT WILL AGILENT OR ITS SUPPLIERS BE LIABLE FOR LOSS OF DATA OR FOR DIRECT, SPECIAL, INCIDENTAL, CONSEQUENTIAL (INCLUDING LOST PROFIT OR DATA), OR OTHER DAMAGE, WHETHER BASED IN CONTRACT, TORT, OR OTHERWISE.

FOR CONSUMER TRANSACTIONS IN AUSTRALIA AND NEW ZEALAND: THE WARRANTY TERMS CONTAINED IN THIS STATEMENT, EXCEPT TO THE EXTENT LAWFULLY PERMITTED, DO NOT EXCLUDE, RESTRICT OR MODIFY AND ARE IN ADDITION TO THE MANDATORY STATUTORY RIGHTS APPLICABLE TO THE SALE OF THIS PRODUCT TO YOU.

---

### U.S. Government Restricted Rights

The Software and Documentation have been developed entirely at private expense. They are delivered and licensed as "commercial computer software" as defined in DFARS 252.227- 7013 (Oct 1988), DFARS 252.211-7015 (May 1991) or DFARS 252.227-7014 (Jun 1995), as a "commercial item" as defined in FAR 2.101(a), or as "Restricted computer software" as defined in FAR 52.227-19 (Jun 1987)(or any equivalent agency regulation or contract clause), whichever is applicable. You have only those rights provided for such Software and Documentation by the applicable FAR or DFARS clause or the Agilent standard software agreement for the product involved.

---

### IEC Measurement Category II Overvoltage Protection

This is a measurement Category II product designed for measurements at voltages up to 300V from earth, including measurements of voltages at typical mains socket outlets. The product should not be used to make voltage measurements on a fixed electrical installation including building wiring, circuit breakers, or service panels.

E1403C and E1407A C-Size Active Adaptor Installation and User's Manual



Edition 4 Rev A  
Copyright © 1997-2006 Agilent Technologies, Inc. All Rights Reserved.

---

---

## Documentation History

All Editions and Updates of this manual and their creation date are listed below. The first Edition of the manual is Edition 1. The Edition number increments by 1 whenever the manual is revised. Updates, which are issued between Editions, contain replacement pages to correct or add additional information to the current Edition of the manual. Whenever a new Edition is created, it will contain all of the Update information for the previous Edition. Each new Edition or Update also includes a revised copy of this documentation history page.

Edition 1 ..... May 1993      Edition 4 Rev 2 ..... July 2006  
Edition 2 ..... January 1995  
Edition 3 ..... December 1996  
Edition 4 ..... March 1997

---

## Trademarks

Microsoft® is a U.S. registered trademark of Microsoft Corporation

Windows NT® is a U.S. registered trademark of Microsoft Corporation

Windows® and MS Windows® are U.S. registered trademarks of Microsoft Corporation

---

## Safety Symbols



Instruction manual symbol affixed to product. Indicates that the user must refer to the manual for specific WARNING or CAUTION information to avoid personal injury or damage to the product.



Alternating current (AC)



Direct current (DC).



Indicates hazardous voltages.



Indicates the field wiring terminal that must be connected to earth ground before operating the equipment—protects against electrical shock in case of fault.

**WARNING**

Calls attention to a procedure, practice, or condition that could cause bodily injury or death.

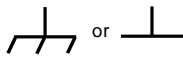

Frame or chassis ground terminal—typically connects to the equipment's metal frame.

**CAUTION**

Calls attention to a procedure, practice, or condition that could possibly cause damage to equipment or permanent loss of data.

---

## WARNINGS

The following general safety precautions must be observed during all phases of operation, service, and repair of this product. Failure to comply with these precautions or with specific warnings elsewhere in this manual violates safety standards of design, manufacture, and intended use of the product. Agilent Technologies, Inc. assumes no liability for the customer's failure to comply with these requirements.

**Ground the equipment:** For Safety Class 1 equipment (equipment having a protective earth terminal), an uninterruptible safety earth ground must be provided from the mains power source to the product input wiring terminals or supplied power cable.

DO NOT operate the product in an explosive atmosphere or in the presence of flammable gases or fumes.

For continued protection against fire, replace the line fuse(s) only with fuse(s) of the same voltage and current rating and type. DO NOT use repaired fuses or short-circuited fuse holders.

**Keep away from live circuits:** Operating personnel must not remove equipment covers or shields. Procedures involving the removal of covers or shields are for use by service-trained personnel only. Under certain conditions, dangerous voltages may exist even with the equipment switched off. To avoid dangerous electrical shock, DO NOT perform procedures involving cover or shield removal unless you are qualified to do so.

**DO NOT operate damaged equipment:** Whenever it is possible that the safety protection features built into this product have been impaired, either through physical damage, excessive moisture, or any other reason, REMOVE POWER and do not use the product until safe operation can be verified by service-trained personnel. If necessary, return the product to an Agilent Technologies Sales and Service Office for service and repair to ensure that safety features are maintained.

**DO NOT service or adjust alone:** Do not attempt internal service or adjustment unless another person, capable of rendering first aid and resuscitation, is present.

**DO NOT substitute parts or modify equipment:** Because of the danger of introducing additional hazards, do not install substitute parts or perform any unauthorized modification to the product. Return the product to an Agilent Technologies Sales and Service Office for service and repair to ensure that safety features are maintained.

---



**Manufacturer's Name:** Agilent Technologies, Incorporated  
**Manufacturer's Address:** 815 – 14<sup>th</sup> St. SW  
Loveland, Colorado 80537  
USA

**Declares, that the product**

**Product Name:** A/B to C-Size Active Adapter  
**Model Number:** E1403B, E1403C, E1407A  
**Product Options:** *This declaration covers all options of the above product(s).*

**Conforms with the following European Directives:**

*The product herewith complies with the requirements of the Low Voltage Directive 73/23/EEC and the EMC Directive 89/336/EEC (including 93/68/EEC) and carries the CE Marking accordingly*

**Conforms with the following product standards:**

<b>EMC</b>	<b>Standard</b>	<b>Limit</b>
	IEC 61326-1:1997+A1:1998 / EN 61326-1:1997+A1:1998 CISPR 11:1990 / EN 55011:1991 IEC 61000-4-2:1995+A1:1998 / EN 61000-4-2:1995 IEC 61000-4-3:1995 / EN 61000-4-3:1995 IEC 61000-4-4:1995 / EN 61000-4-4:1995 IEC 61000-4-5:1995 / EN 61000-4-5:1995 IEC 61000-4-6:1996 / EN 61000-4-6:1996 IEC 61000-4-11:1994 / EN 61000-4-11:1994	Group 1 Class A 4kV CD, 8kV AD 3 V/m, 80-1000 MHz 0.5kV signal lines, 1kV power lines 0.5 kV line-line, 1 kV line-ground 3V, 0.15-80 MHz 1 cycle, 100%
	Canada: ICES-001:1998 Australia/New Zealand: AS/NZS 2064.1	
<b>Safety</b>	IEC 61010-1:1990+A1:1992+A2:1995 / EN 61010-1:1993+A2:1995 Canada: CSA C22.2 No. 1010.1:1992	

**Supplemental Information:**

*The product was tested in a typical configuration with Agilent Technologies test systems.*

March 12, 2001  
Date

**Ray Corson**  
Product Regulations Program Manager

For further information, please contact your local Agilent Technologies sales office, agent or distributor.  
*Authorized EU-representative: Agilent Technologies Deutschland GmbH, Herrenberger Strabe 130, D 71034 Böblingen, Germany*

*Notes:*

---



*Notes:*

---

*Notes:*

---

## Introduction

The manual is separated into the following chapters.

**Chapter 1 - General Information.** Describes the different adapters.

**Chapter 2 - Installation/Removal Instructions.** This chapter shows how to install/remove B-Size VXIbus modules into/from the Agilent E1403C or Agilent E1407A C-Size Adapter Module, and how to install/remove the adapter module into a C-Size VXIbus Mainframe.

**Chapter 3 - Using the Adapters.** This chapter shows how to use the adapter modules. It includes a block diagram for both the Agilent E1403C and Agilent E1407A Adapter Modules. The chapter also includes, for the Agilent E1407A Adapter Module, instructions on how to use and install the J2 Connector Cable, how to select the direction (to or from the mainframe's backplane) of the trigger signals on the ECL and TTL trigger lines, and how to select unbuffered or buffered SUMBUS connections. Connector pinout diagrams for both the Agilent E1403C and E1407A are also provided.

**Appendix A - Specifications.** This appendix details specifications for the Agilent E1403C and Agilent E1407A C-Size Adapter Module.

## C-Size Adapter Description

The Agilent E1403C and Agilent E1407A Adapter Modules allow an A- or B-Size VMEbus/VXIbus module to connect to a C-Size VXIbus Mainframe. The regular adapters connect a single slot VMEbus/VXIbus module to the mainframe. Option 10 connects two-slot modules to the mainframe (however, it only connects the module to the P1 and/or P2 connector of only one slot). The following gives the features of the adapters.

### Agilent E1403C Adapter Description

Use this adapter to make buffered connections between an A-size or B-size module's J1 connector and the mainframe's P1 connector. The adapter has the following features:

- Mounts with the VMEbus/VXIbus module's front panel flush with the front of the adapter.
- Provides direct access to the VMEbus/VXIbus module's front panel I/O connections.
- Provides connections to the J1 connector with pin-to-pin compatibility to the mainframe's P1 connector.

- Meets VMEbus driving and loading specifications.
- Provides proper timing for data Transfer Acknowledgment (DTACK) and Interrupt Signals (IRQ).
- Provides connectivity for Agilent B-size modules or any P1-only VXIbus slave module (Bus Master signals are not provided. These include: BBSY\*, BLCR\*, BR0\*, BR1\*, BR2\*, BR3\*, SERCLK, SERDAT.)

## Agilent E1407A Adapter Description

Use this adapter to make buffered connections between an A-size or B-size module's J1 connector and the mainframe's P1 connector, and buffered connections between a B-size module's J2 connector and the mainframe's P2 connector. The adapter has the following features:

- Mounts with the VMEbus/VXIbus module's front panel flush with the front of the adapter.
- Provides direct access to the VMEbus/VXIbus module's front panel I/O connections.
- Provides connections to the J1 connector with pin-to-pin compatibility to the mainframe's P1 connector.
- Provides direct connections to the J2 connector with pin-to-pin compatibility to the mainframe's P2 connector.
- Provides buffered data, address, and trigger lines (either ECL or TTL).
- Provides direct SUMBUS connections, or provides fused  $\pm 12$  V power supply connections to add user provided circuitry (op-amps, for example) for buffered SUMBUS connections (jumper selectable).
- Provides access to the pins on the outer rows of the J2 connector for VME modules. These pins may be isolated from the backplane.
- Meets VMEbus driving and loading specifications.
- Provides proper timing for data Transfer Acknowledgment (DTACK) and Interrupt Signals (IRQ).
- Provides connectivity for Agilent B-size modules or any P1-only VXIbus slave module (Bus Master signals are not provided. These include: BBSY\*, BLCR\*, BR0\*, BR1\*, BR2\*, BR3\*, SERCLK, SERDAT.)

# Chapter 2

## Installation/Removal Instructions

---

This chapter shows how to install/remove B-size VXIbus modules into/from the Agilent E1403C or Agilent E1407A C-Size Adapter Module, and how to install/remove the adapter module into a C-Size VXIbus Mainframe.

---

**Note** The procedures in this chapter shows installation/removal of the Adapter Module into/from the Agilent E1401A High Power Mainframe. The procedures for other mainframes are similar to these procedures.

---

### Preparing for Installation

- Be sure to set the logical address of the module to be installed into the adapter to the correct address (see the module manual).
- Be sure to use clean handling and anti-static handling of the module.
- Be sure there are no external connections to the modules.

### Installing A-Size VMEbus Modules (Agilent E1403C Only)

Install A-Size VMEbus Modules only in the Agilent E1403C Adapter Module. Use the following B-Size Module installation procedure to install an A-Size Module into the adapter module.

# Installing an Adapter Module with a B-Size VXIbus Module

The procedure starting on the next page shows how to install an Agilent E1403C or Agilent E1407A C-Size Adapter Module into an Agilent E1401A Mainframe. (The installation procedures for other mainframes is similar.) The procedure then shows how to install a B-Size VXIbus Module into the adapter module.

---

**Note** During power-up, the resource manager recognizes a module in the slot with the Agilent E1403C or Agilent E1407A Adapter Module installed with or without a B-Size module installed in the adapter module. Thus, to prevent any error generation, be sure a B-Size module is installed in the adapter module before power-up.

---

## 1 Line up the C-Size Adapter Module's Rails with the Module Guides of an Empty Slot in the Mainframe.

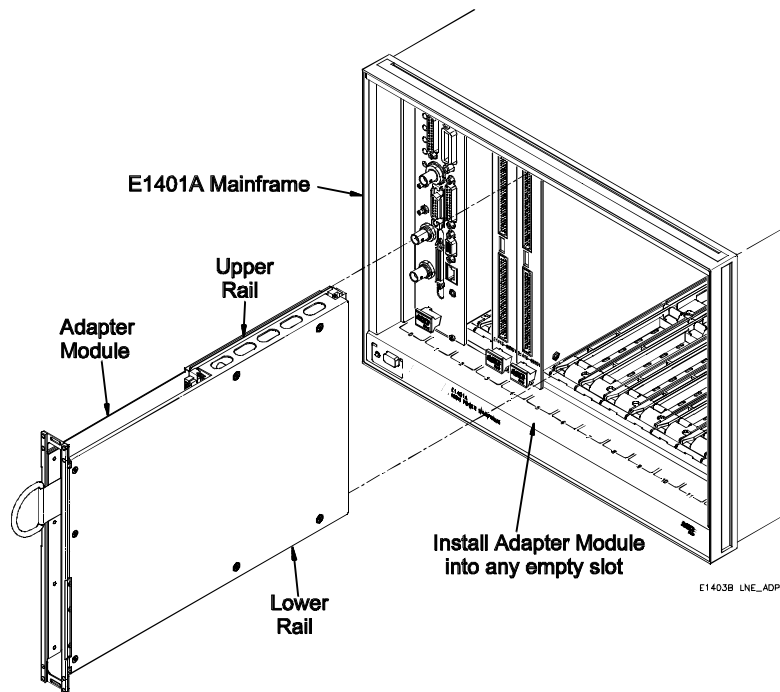

**2** Slide the C-Size Adapter Module into the Mainframe.

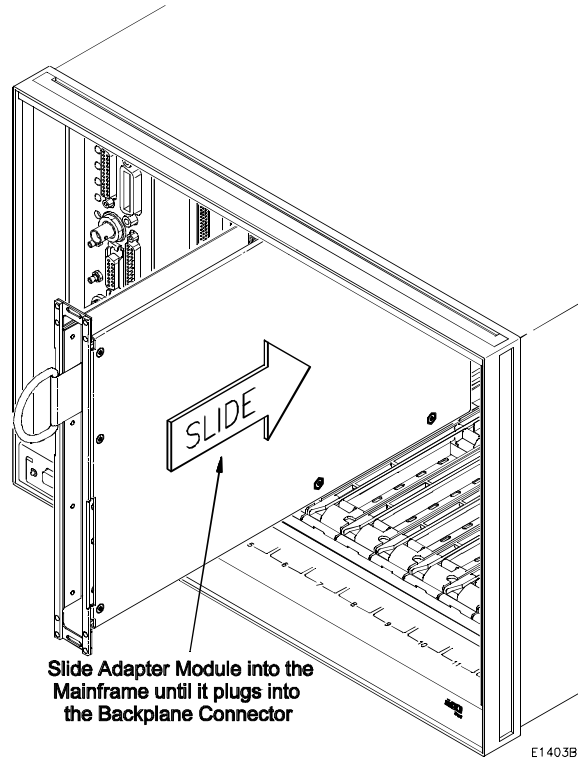

**3** Line up the B-Size Module with the C-Size Adapter Module's Front Slot and the Mainframe's Module Guides.

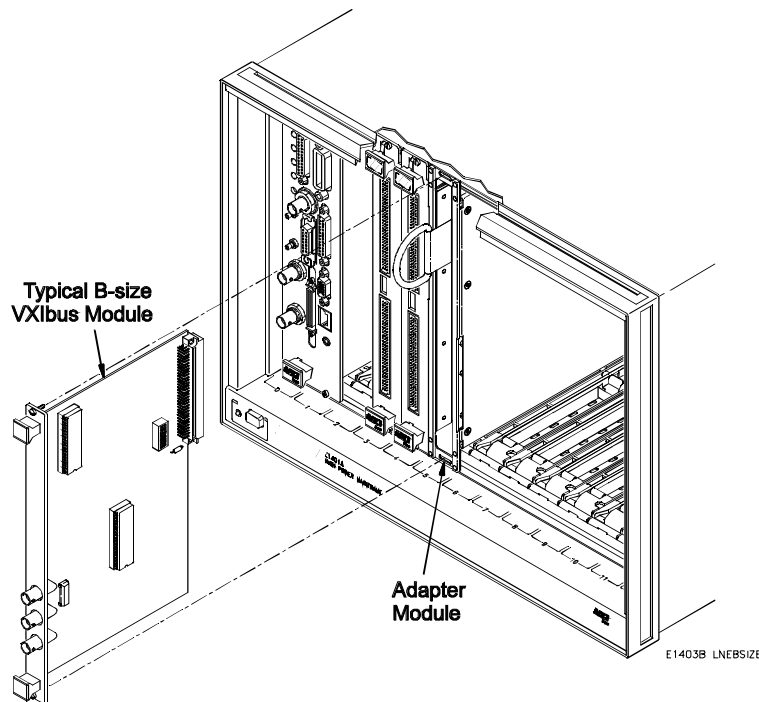

#### 4 Slide the B-Size Module into the C-Size Adapter Module.

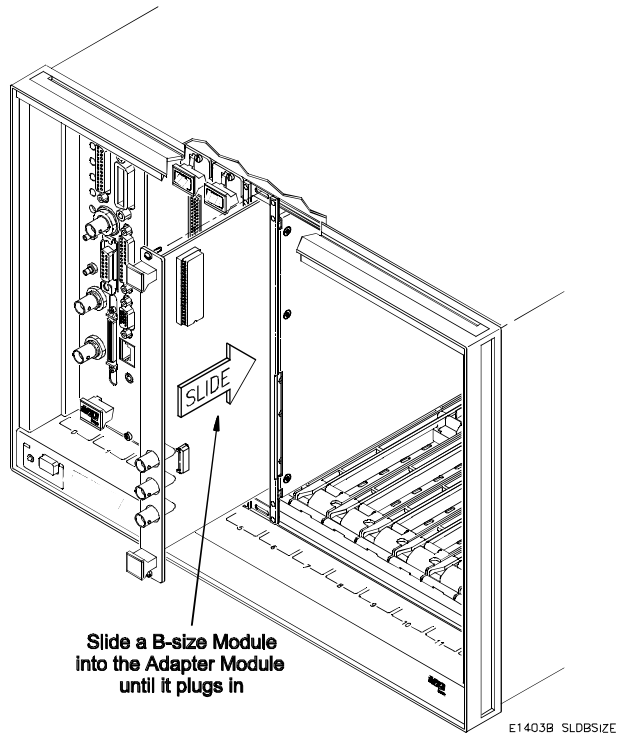

#### 5 Tighten the B-Size Module's Upper and Lower Retainer Screws.

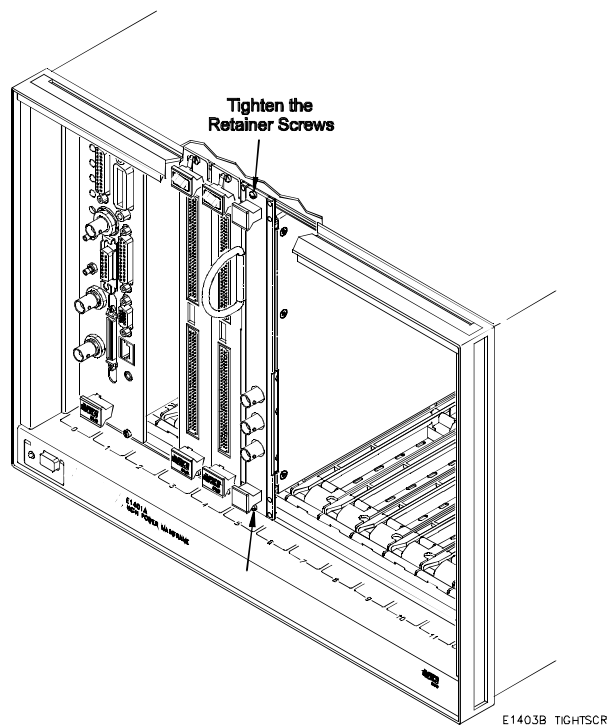



# Removing the Adapter Module and B-Size Module

The following procedure shows how to remove a B-Size VXIbus Module from an Agilent E1403C or Agilent E1407A C-Size Adapter Module and the adapter module from the mainframe.

- 1 Loosen the Upper and Lower Retainer Screws of the B-Size Module inside the C-Size Adapter Module.**

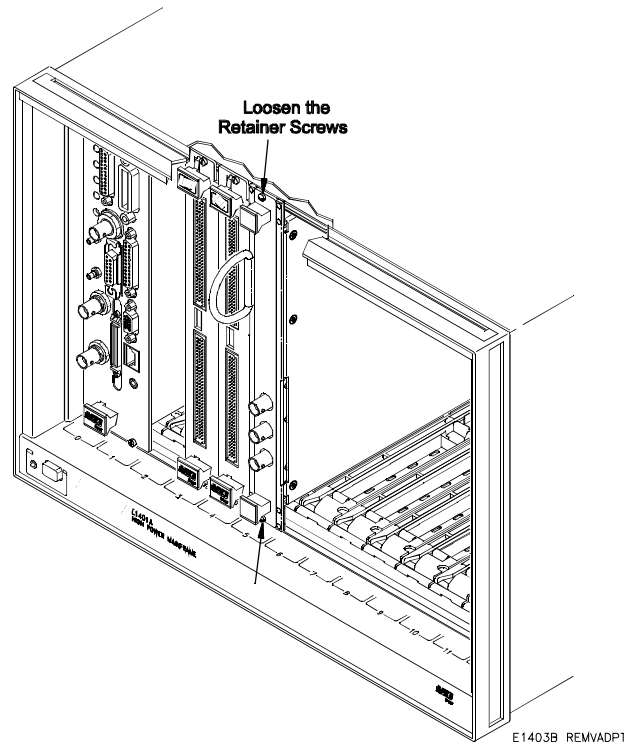

*Continued on Next Page*

## 2 Using the handles on the B-Size Module, pull the Module out of the C-Size Adapter Module.

### NOTE:

When removing the B-size Module from the Adapter Module, the Adapter Module may be pulled out of the mainframe. If that happens, carefully pull the B-size Module out of the Adapter Module, without damaging any exposed components on the B-size Module.

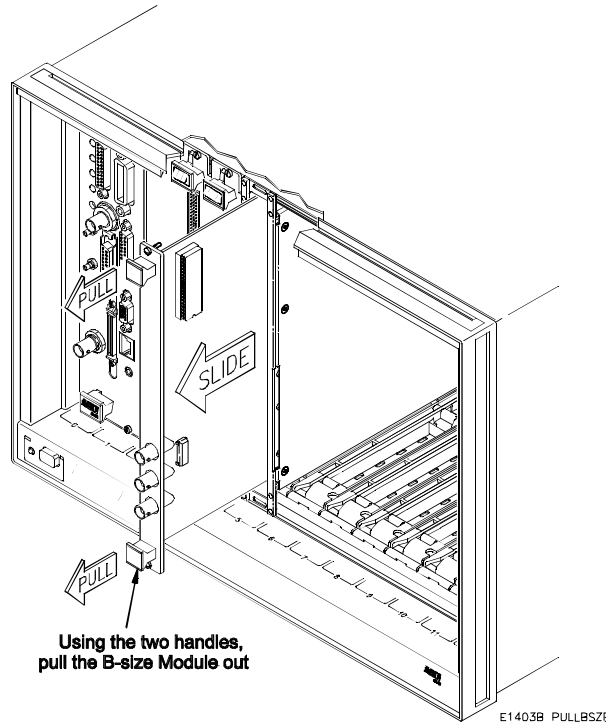

## 3 Using the "D" Ring, pull the C-Size Adapter Module out of the Mainframe.

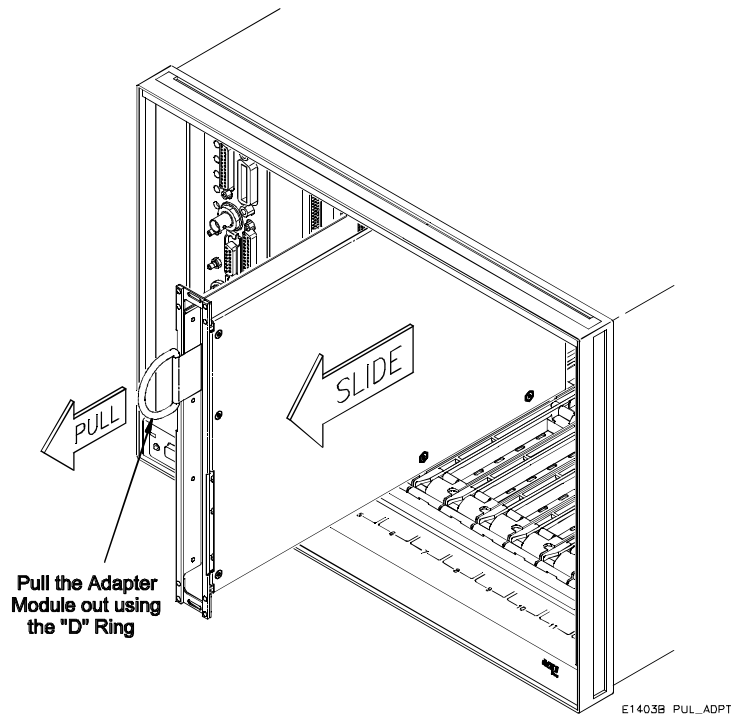

# Chapter 3

## Using the Adapters

---

This chapter shows how to use the adapter modules. It includes a block diagram for both the Agilent E1403C and Agilent E1407A Adapter Modules as well as connector pinouts. This chapter also includes, for the Agilent E1407A Adapter Module, instructions on how to use and install the J2 connector cable, how to select the direction (to or from the mainframe's backplane) of the trigger signals on the ECL and TTL trigger lines, and how to select unbuffered or buffered SUMBUS connections.

### Agilent E1403C Block Diagram

Figure 3-1 shows the block diagram for the Agilent E1403C C-Size Adapter Module.

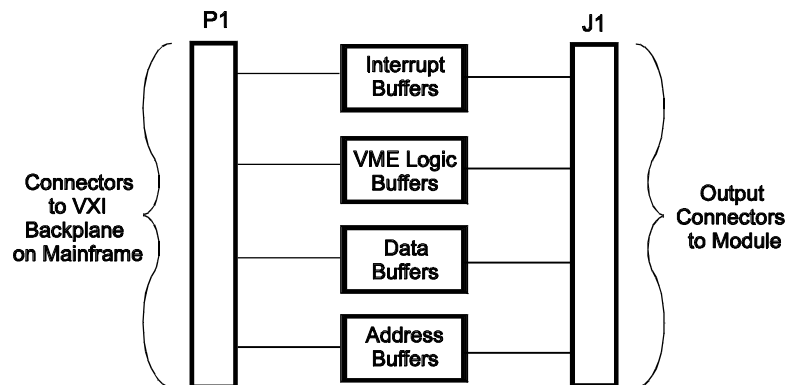

Figure 3-1. Agilent E1403C Block Diagram

# Agilent E1403C Connector Pinout

Figure 3-2 shows the P1 and J1 connector's pinout for the Agilent E1403C Adapter Module.

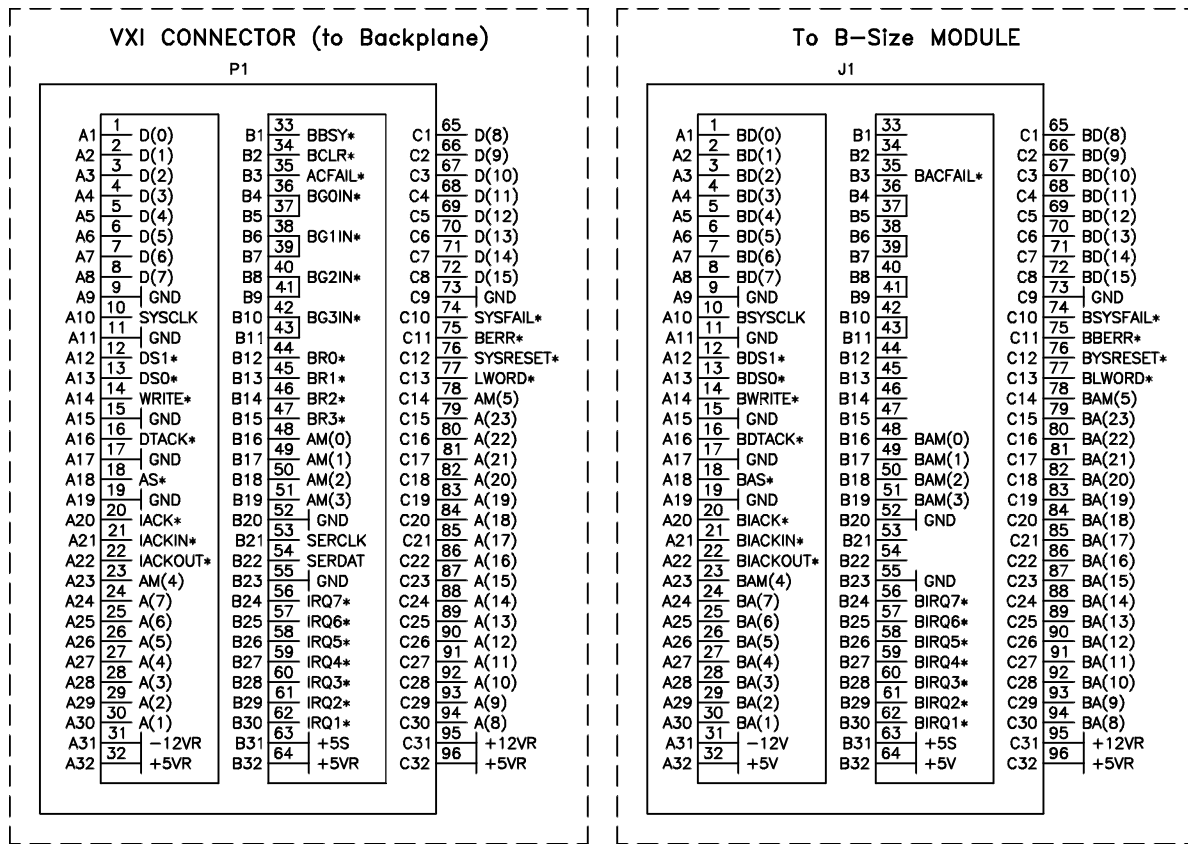

Figure 3-2. Agilent E1403C P1 and J1 Connector Pinout

# Agilent E1407A Block Diagram

Figure 3-3 shows the block diagram for the Agilent E1407A C-Size Adapter Module.

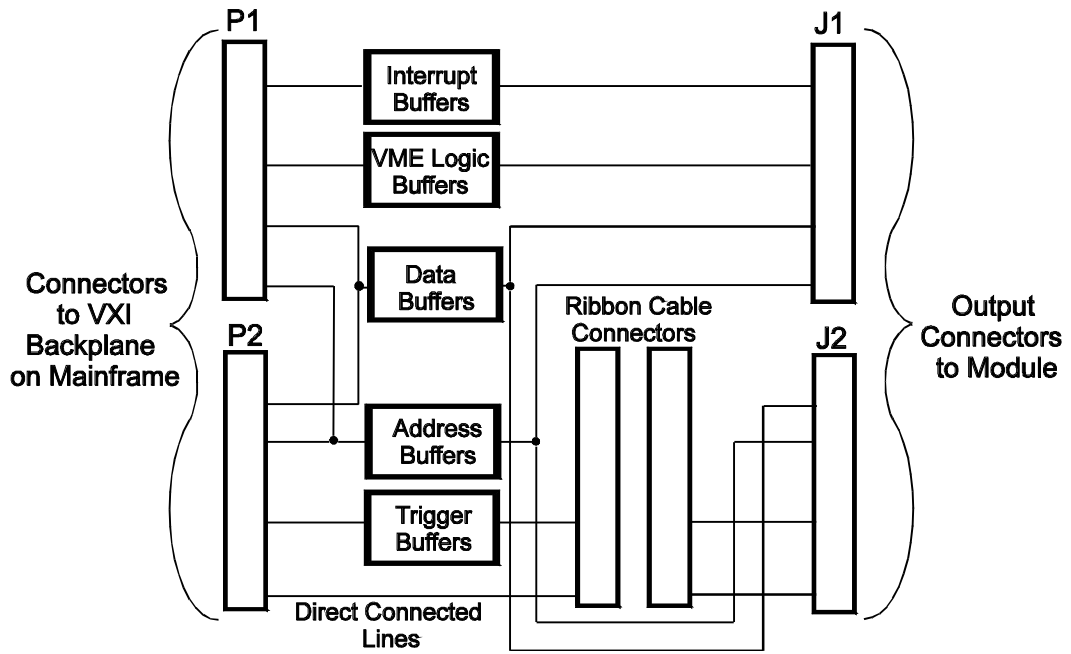

Figure 3-3. Agilent E1407A Block Diagram

# Agilent E1407A Connector Pinout

Figure 3-4 shows the P1 and J1 connector's pinout, and Figure 3-5 shows the P2 and J2 connector's pinout for the Agilent E1407A Adapter Module.

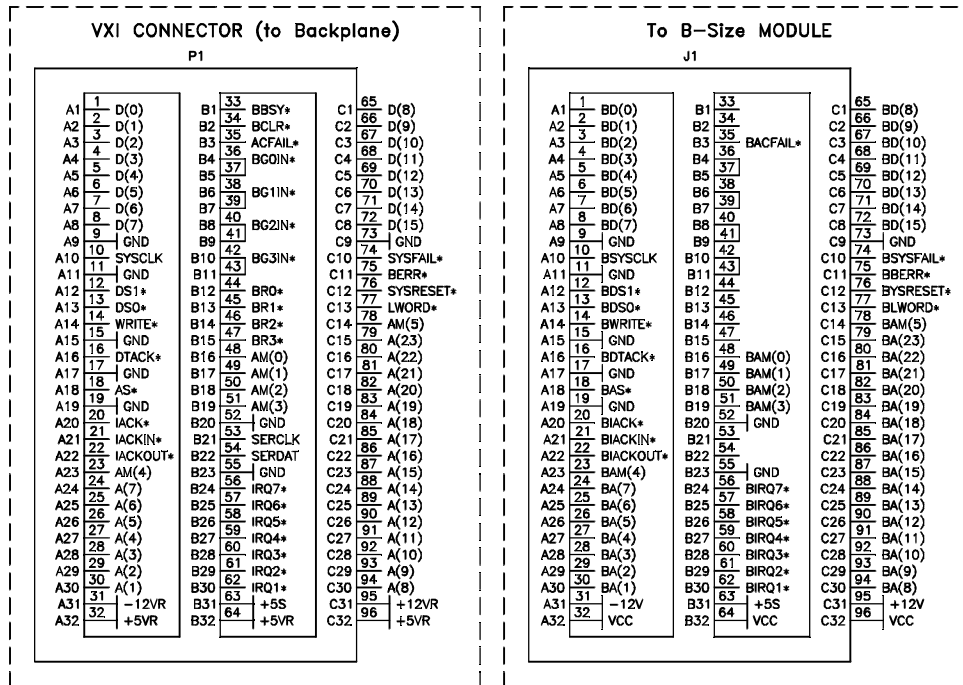

Figure 3-4. Agilent E1407A P1 and J1 Connector Pinout

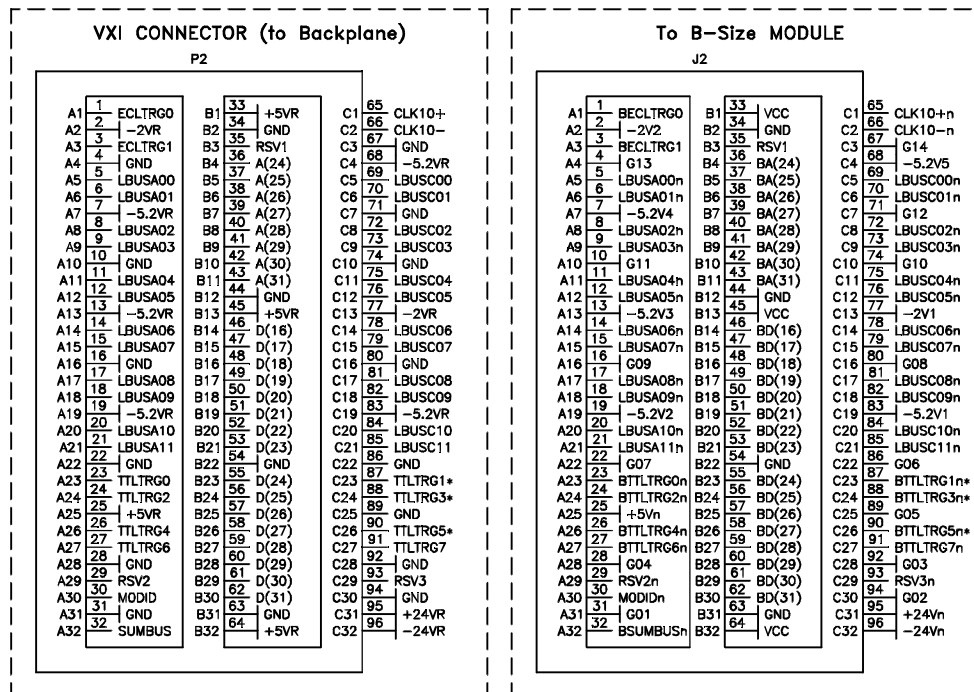

Figure 3-5. Agilent E1407A P2 and J2 Connector Pinout

# Installing the J2 Connector Cable (Agilent E1407A Only)

## Purpose of the J2 Cable

The Agilent E1407A C-Size Adapter Module is shipped with a long and short J2 Connector Cables. The long J2 cable allows for direct access to the outer rows of the J2 connector of the B-Size module (that is, VMEbus modules that utilize the outer rows of J2) inside the adapter module. The short J2 cable makes internal connections between the P2 and J2 connectors of the adapter module to allow for connections between the J2 connector of the B-Size module inside the adapter module and the P2 connector of the mainframe. Use this for VXIbus modules that utilize the outer rows of J2. If your module has no outer row connections of J2, do not install either cable.

See Figure 3-6 for the J2 connector's pinout diagram.

---

**Caution** Damage to a VMEbus module, adapter module, mainframe, or all three may result if using the short cable in an adapter module with a VMEbus module.

---

**Install the J2 Cable** Do the following to install either J2 Cable:

- 1 On the C-Size VXIbus Adapter Module, remove the 7 Top Shield Retainer Screws and Top Shield.**

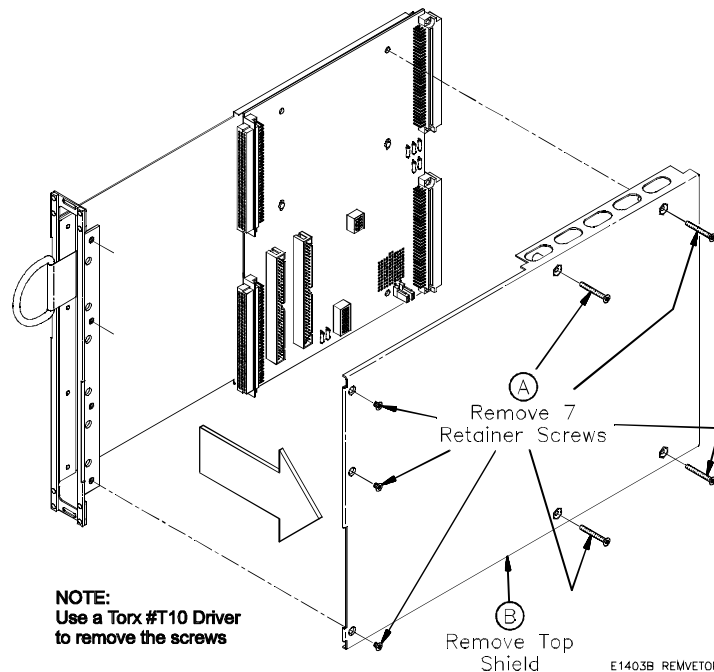

## 2 Plug in either the Short or Long Ribbon (J2) Cable.

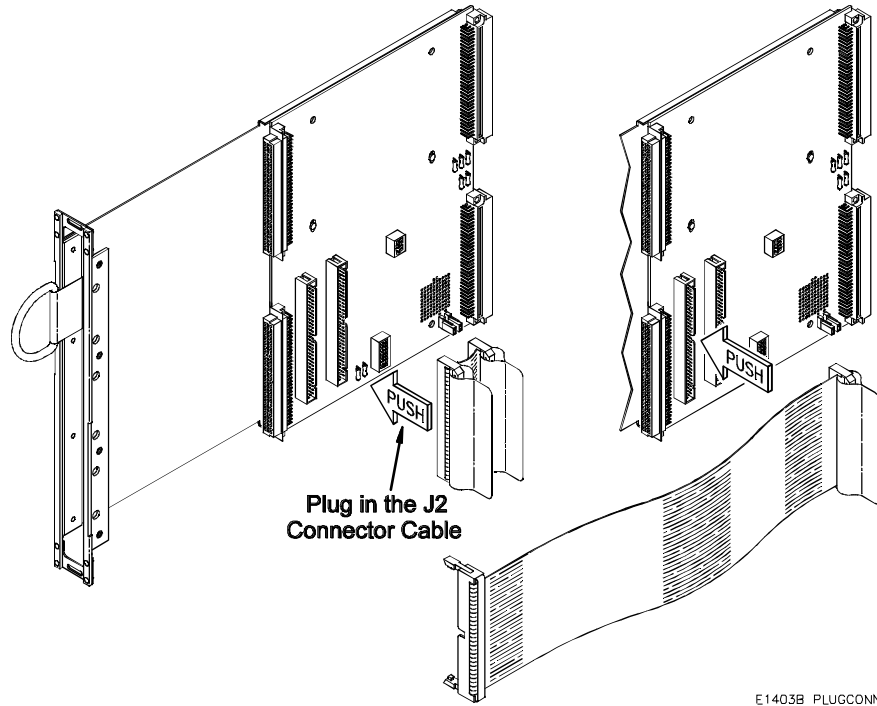

## 3 Reinstall the Top Shield and Retainer Screws on the C-Size Adapter Module.

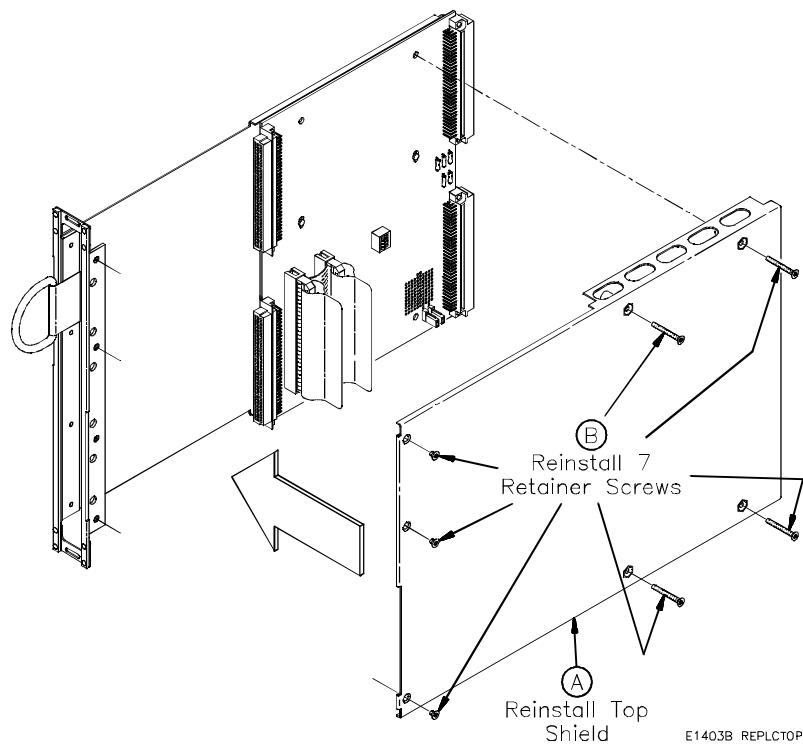



# Ribbon Cable (J2) Connector Pinout

Figure 3-6 shows the pinout for the Agilent E1407A ribbon cable connectors (J2).

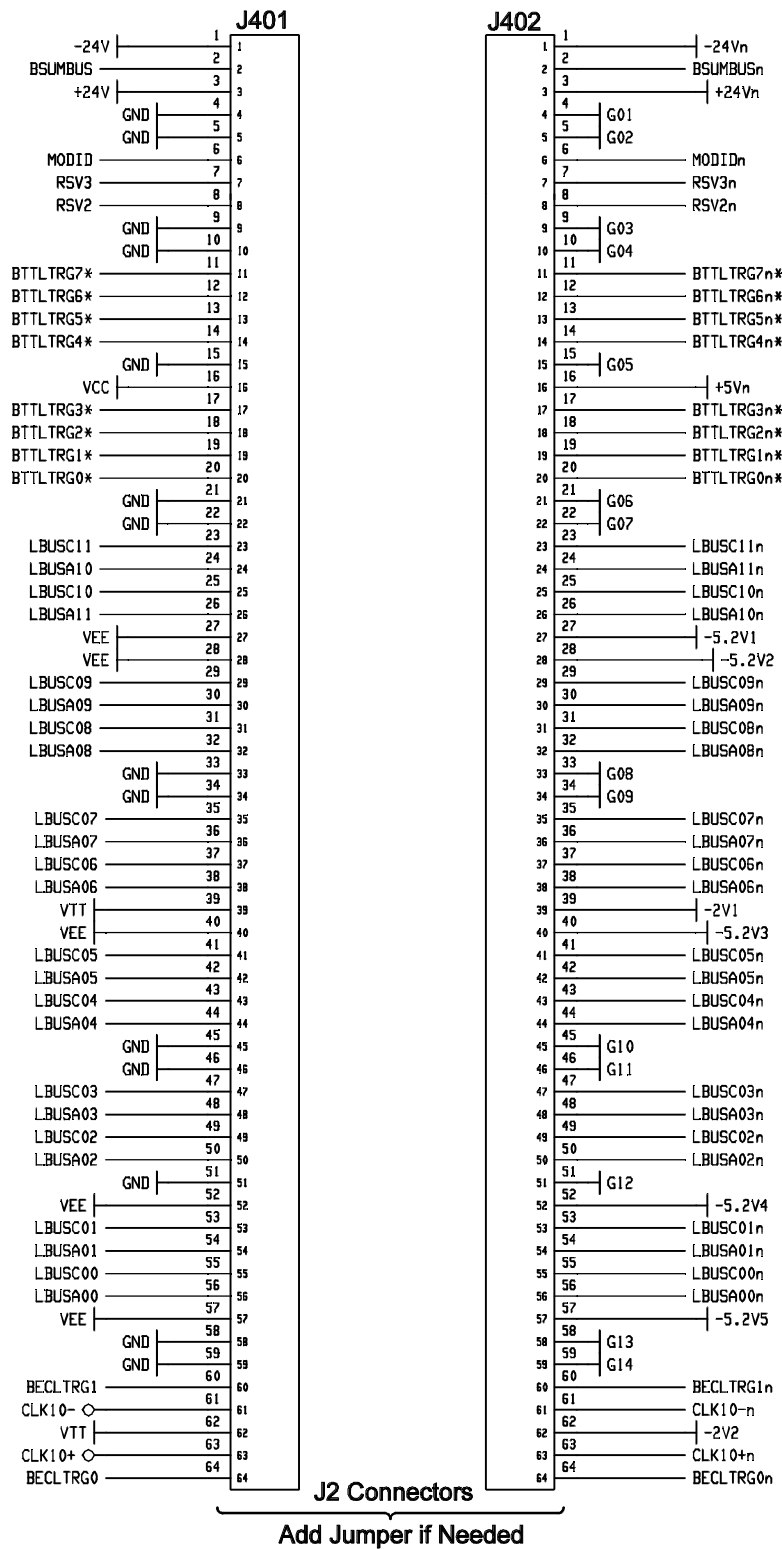
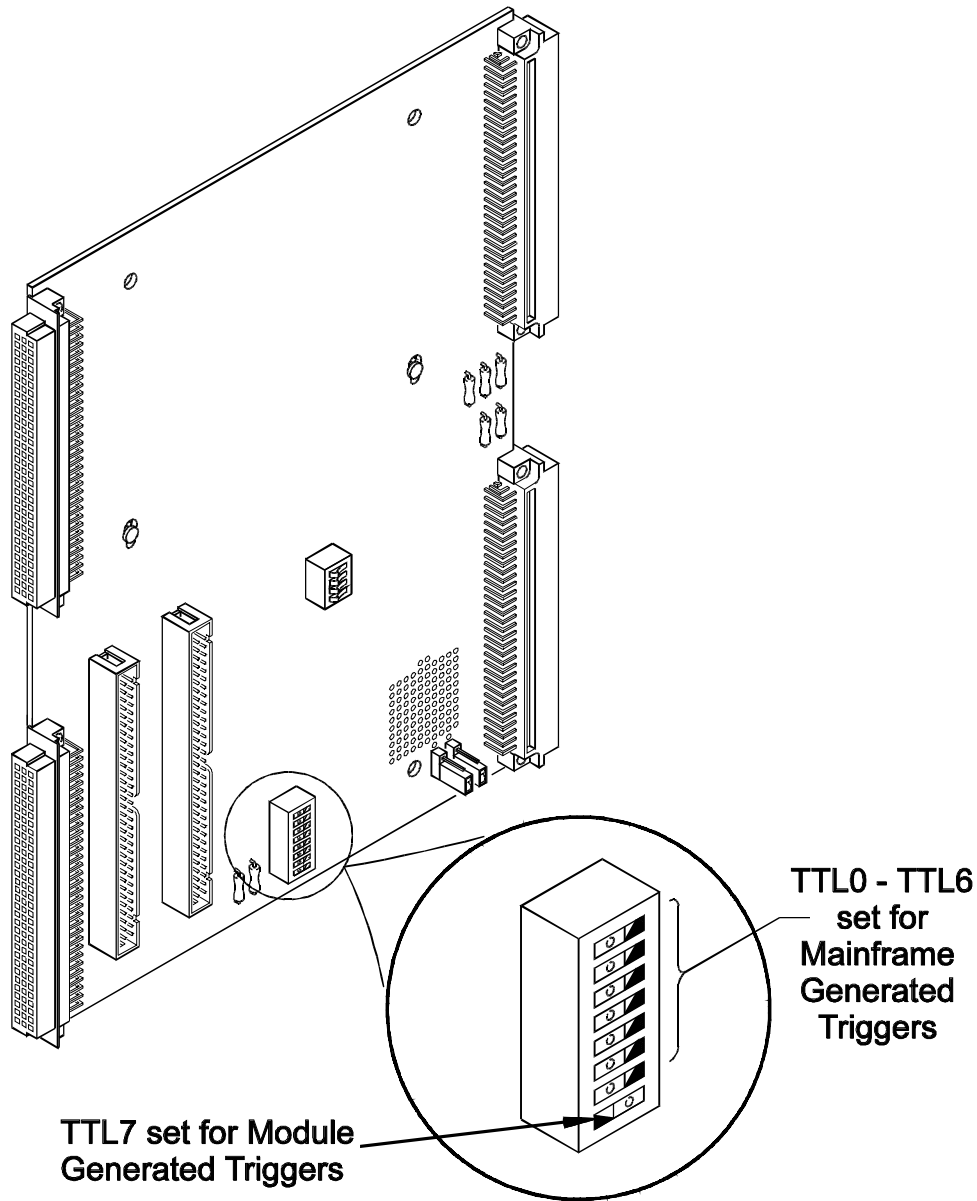

Figure 3-6. Agilent E1407A Ribbon Cable Connectors (J2)

# Selecting the TTL Trigger Direction (Agilent E1407A Only)

The Agilent E1407A C-Size Adapter Module has a switch that allows you to set the trigger signal direction of the TTL0–TTL7 Trigger Lines. Figure 3-7 shows that the TTL7 Trigger Signal comes from the B-Size Module, and TTL0–TTL6 from the Mainframe's VXI Backplane. Use the illustration as a guide to set the appropriate trigger directions for your application.



E1403B 1407\_SW8

Figure 3-7. Selecting the TTL Trigger Signal Direction

# Selecting the ECL Trigger Direction (Agilent E1407A Only)

The Agilent E1407A C-Size Adapter Module has a switch that allows you to set the trigger signal direction of the ECL0 and ECL1 Trigger Lines. Figure 3-8 shows that the ECL1 Trigger Signal comes from the B-Size Module, and ECL0 from the Mainframe's VXI Backplane. Use the illustration as a guide to set the appropriate trigger directions for your application.

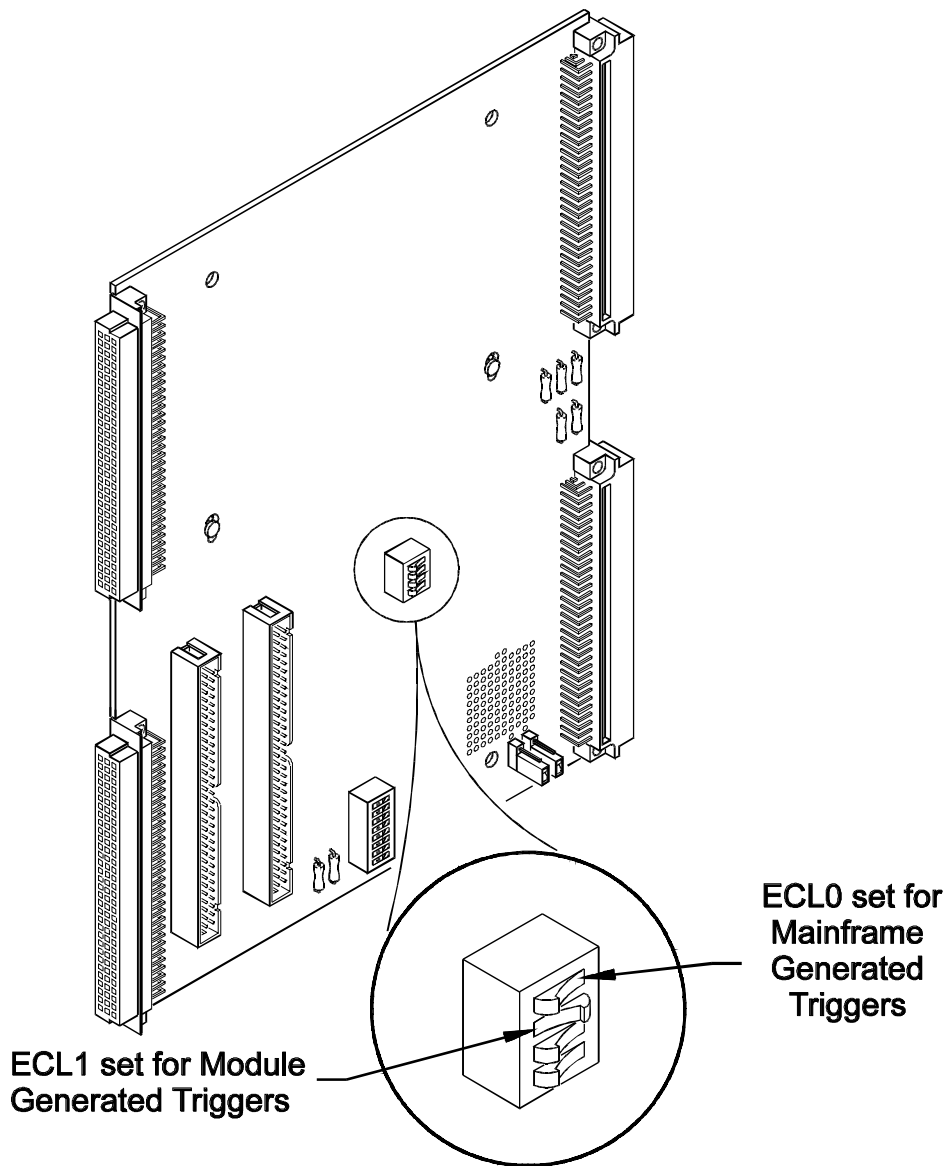

E1403B 1407\_SW

Figure 3-8. Selecting the ECL Trigger Signal Direction

# SUMBUS Configurations (Agilent E1407A Only)

## Disconnecting the SUMBUS

The ribbon cable and a pair of jumpers connect the SUMBUS to the output connectors (i.e., to the B-Size Module). Use Figure 3-9 to disconnect (i.e., remove the jumpers) or connect the SUMBUS.

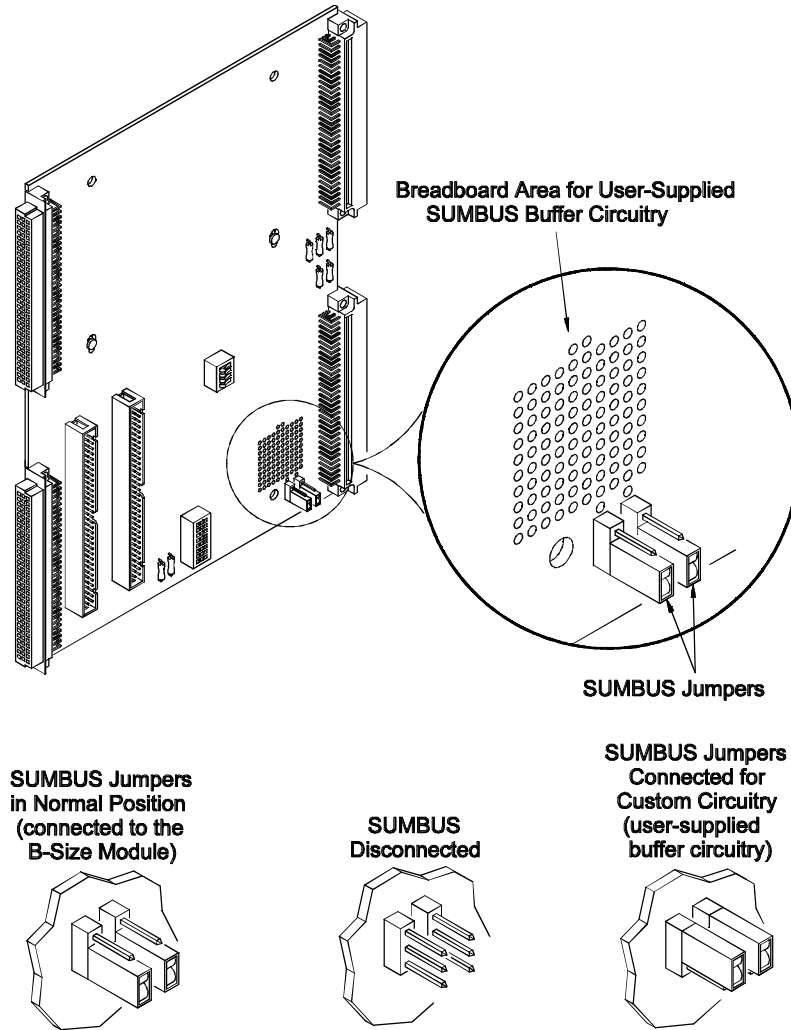

Figure 3-9. SUMBUS Jumper Configurations

## Adding Buffer Circuitry to the SUMBUS

The adapter module has no circuitry available to buffer the SUMBUS. However, there is a breadboard area on the PC board in the Agilent E1407A Adapter that allows you to add your own circuitry (e.g., op-amps) to provide buffering for the SUMBUS. The breadboard area also includes connections to the  $\pm 12V$  Power Supplies.

You can add buffer circuitry either for SUMBUS signals coming from the B-Size Module in the Adapter Module or from the Mainframe's VXI Backplane. Use Figure 3-9 to select the appropriate jumpers for your application, and to locate the breadboard area.

# Appendix A

# Agilent E1403C and E1407A Specifications

---

## Product Characteristics

- P1 and P2 extension fully buffered (P1 only on Agilent E1403C).
- Slave-only capability; cannot be used in Slot 0 with bus masters.
- Unlimited number of adapters per mainframe.
- 1-slot wide.
- Option 10 is 2-slot wide. Only the P1 and/or P2 connectors of a single slot are used.
- Replacement fuses are subminiature 4A, 125V (Littelfuse is recommended).

## Power Requirements

<u>Voltage:</u>	<u>+5V</u>	<u>+12V*</u>
Peak Module Current (A):	0.10	0.07
Dynamic Module Current (A):	0.01	0.01

\* Agilent E1407A Only

## Cooling Requirements

0.02mm H<sub>2</sub>O @0.10Liter/sec Air Flow for 10° C rise.

*Notes:*

---

**A**

- Adapter Description, 9
  - Agilent E1403C, 9
  - Agilent E1407A, 10
  - option 10, 9
- Adding SUMBUS Buffer Circuitry, 26
- A-Size VMEbus Modules, installing, 11

**B**

- Backplane
  - ECL trigger signals, 25
  - SUMBUS buffer circuitry, 26
  - TTL trigger signals, 24
- Block Diagram
  - Agilent E1403C, 17
  - Agilent E1407A, 19
- B-Size VXIbus Modules
  - ECL trigger signal, 25
  - installing, 12–14
  - removing, 15–16
  - SUMBUS buffer circuitry, 26
  - TTL trigger signal, 24

**C**

- Cable
  - ribbon cable (J2)
    - description, 21
    - installing, 21, 23
    - pinouts, 23
- Certification, 3
- Connecting the SUMBUS, 26
- Cooling Requirements, 27

**D**

- Declaration of Conformity, 5
- Description
  - adapters, 9
  - Agilent E1403C, 9
  - Agilent E1407A, 10
    - ECL trigger, 25
    - ribbon cable (J2), 21, 23
    - SUMBUS, 26
    - TTL trigger, 24

- Description (*continued*)
  - option 10, 9
  - ribbon cable (J2), 21, 23
- Disconnecting the SUMBUS, 26
- Documentation History, 4

**E**

- ECL Trigger Direction, 25

**F**

- Fuses, 27

**H**

- Agilent E1403C
  - A-size VMEbus modules, installing, 11
  - block diagram, 17
  - B-size VXIbus modules
    - installing, 12–14
    - removing, 15–16
  - description, 9
  - pinout, 18
  - specifications, 27
- Agilent E1407A
  - block diagram, 19
  - B-size VXIbus modules
    - ECL trigger signals, 25
    - installing, 12–14
    - removing, 15–16
    - SUMBUS buffer circuitry, 26
    - TTL trigger signals, 24
  - description, 10
  - ECL trigger direction, 25
  - pinout, 20
    - ribbon cable (J2), 23
  - ribbon cable (J2), installing, 21, 23
  - specifications, 27
  - SUMBUS, 26
  - TTL trigger direction, 24

## I

### Installation

- and removal instructions, 11
- A-size VMEbus modules, 11
- B-size VXIbus modules, 12–14
- Agilent E1407A, ribbon cable (J2), 21, 23
- preparation, 11

## M

### Mainframe

- backplane
  - ECL trigger signals, 25
  - SUMBUS buffer circuitry, 26
  - TTL trigger signals, 24
- installing
  - A-size VMEbus modules, 11
  - B-size VXIbus modules, 12–14
- removing modules from, 15–16

## O

- Option 10, description, 9

## P

### Pinouts

- Agilent E1403C, 18
- Agilent E1407A, 20
  - ribbon cable (J2), 23

### Power Requirements, 27

### Preparing for Installation, 11

## R

### Removing B-size VXIbus Modules, 15–16

### Ribbon Cable (J2)

- description, 21
- installing, 21, 23
- pinouts, 23

## S

### Safety Warnings, 4

### Selecting

- ECL trigger direction, 25
- TTL trigger direction, 24

### Specifications, 27

### SUMBUS

- adding buffer circuitry, 26
- configurations, 26

### Switches

- ECL trigger, 25
- TTL trigger, 24

## T

### Triggers

- B-size modules, 24–25
- ECL, 25
- mainframe VXI backplane, 24–25
- TTL, 24
  - trigger direction, 24

## U

### Using the Adapters, 17

## V

### VXIplug&play Example Programs

- See *VXIplug&play* Online Help

### VXIplug&play Function Reference

- See *VXIplug&play* Online Help

### VXIplug&play Programming

- See *VXIplug&play* Online Help

### VXIplug&play Soft Front Panel

- See *VXIplug&play* Online Help

## W

### WARNINGS, 4